

RT20 PA Series AC Servo Drive

User Manual 400VAC



A&TS TECHNOLOGY CORPORATION LIMITED

<https://www.a-ts.net>

DECLARATION

Without written permission, reprint or copy is strictly forbidden. Unauthorized copying, dissemination or use of this document and its contents is prohibited. Violators will be liable for compensation.

All rights, including the rights granted by patent rights and the registration rights of application models or designs will be reserved.

The information provided in this publication will be updated regularly, and any necessary corrections will be implemented in subsequent releases. Suggestions for improvement are welcome at any time.

Version	Product	Release Date	Note
V-23-01	RT20	24.03.2023	N/A
V-24-01	RT20	26.01.2023	N/A
V-26-01	RT20-PA	19.03.2026	N/A

Forward

The RT20 series AC servo is provided by the A&TS Technology Corporation Limited in China.

To have a thorough understanding, please read this manual carefully and follow all safety precautions before moving, installing, operating and maintaining the servo.

This manual provides guidance on safety precautions, product specifications, installation and wiring, keyboard operation, parameter settings, alarms, trouble-shooting, routine maintenance etc. It doesn't include all the security matters or considerations.

Local laws and regulations

All the local laws, regulations, and codes of practice should be obeyed first, besides the instructions in the manual.

Disclaimer of Liability



We have reviewed the contents of this publication to ensure consistency with the hardware and software described.

Since variance cannot be precluded entirely, we cannot guarantee full consistency. However, the information in this publication is reviewed regularly and any necessary corrections are included in subsequent editions.

Thank you for choosing A&TS.

A&TS, automation technologies, at your services.

In this document, the following symbols may appear. The represented meaning is as follows.

Symbol	Instructions
	<p>Attention, please! If there is improper operation, it may cause serious consequences such as personal safety, equipment safety or environmental safety.</p>
	<p>Be careful! If there is improper operation, it may cause major accident, such as equipment damage or physical injury.</p>
	<p>If there is misoperation, it may cause bad effects or cannot be operated normally. Generally speaking, the issues caused could be solved.</p>
<p>INSTRUCTIONS</p>	<p>It is widely used. It reminds the instructions and prompts.</p>
<p>EXAMPLE</p>	<p>For the better understanding of the users, to show a brief example</p>
<p>NOTE</p>	<p>It indicates small functions and tips unnoticeable that are very convenient to use.</p>

1 Safety Precautions

1.1 General precautions

This manual provides guidance on safety precautions, product specifications, installation and wiring, keyboard operation, parameter settings, alarms, trouble-shooting, routine maintenance etc. It doesn't include all the security matters or considerations.

When installing, operating, and maintaining the RT20 series ac servo, please follow all the safety instructions in this manual, especially where there is safety symbols. All the safety symbols are the tips to the safety precautions. It doesn't include all the security matters or considerations.

For any injury or loss caused by improper operation, the A&TS technology will not take the responsibility. The A&TS technology is not legally bound in any manner either.

Basic installation requirement

- Only qualified or strictly trained engineers are allowed to install, operate and maintain equipment.
- Only qualified professionals are allowed to dismantle devices and repair equipment.
- Replacing or changing hardware and software must be carried out by the authorized engineers.
- The operator shall report the failure or error to the person in charge in time promptly.

Grounding requirement

The following requirements are for devices that need to be grounded only.

- Before installing the equipment, grounding first. When removing the equipment, keep the grounding until the end.
- It is forbidden to damage the grounding conductor.
- It is forbidden to operate equipment without the grounding conductor.
- The equipment shall be grounded always. Before operating, make sure the electrical connection is fine and reliable.

Equipment safety

- Before operation, the equipment should be fixed in the electric cabinet or on other stable objects firmly, such as the table or floor.
- When the system is running, make sure the air vent is unobstructed.
- When installing the equipment, to tighten the screws, use the tool.
- After complete the installation, please take all the empty packing materials area away.

2 Product Information

2.1 Product introduction

RT20 series servo is all digital ac servo drive, with high reliability, performance and cost effectiveness.

- High voltage servo, working at three phases 380VAC, with high voltage motor.
- Supports position control, speed control and torque control mode.
- Supports ABZ incremental encoder, standard incremental encoder,

absolute encoder including Tamagawa, Panasonic, BISS, EnDat and Nikon, and ME (magnetolectricity encoder).

- Supports RS485 communication, standard Modbus protocol.
- Supports internal speed mode and demonstration running mode.



WARNING

The standard version of the RT servo is intended for industrial applications. Please do not use it on equipment that may endanger personal safety. If the user needs to apply it to specific applications such as medical or aerospace equipment, please contact A&TS.

2.2 Model designation

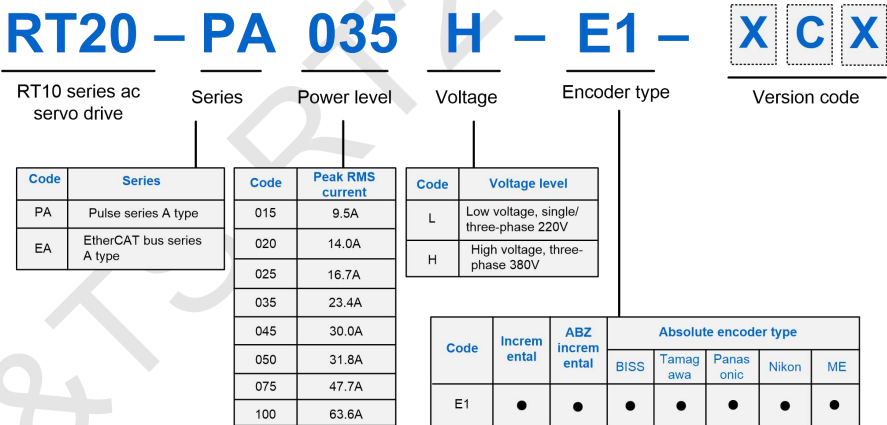

Figure 2-1 RT20 series AC servo drive naming rule

INSTRUCTIONS

- Support this feature.
- × Don't support this feature.

Version code: In XCX, X represents the default configuration model, B represents type B, and C represents type C.

2.3 Technical specifications

Table 2- 1 RT20 PA series pulse series technical specification

Model	RT20 PA series AC Servo Drive							
RT20-PA□□□H-XC	015	020	025	035	045	050	075	100
Power supply	Three-phase AC380V-440V, -15%~+10%, 50/60Hz							
Rated current (A)	3.8	5.4	6.7	8.4	12.0	12.7	18.0	25.0
Peak RMS current (A)	9.5	14.0	16.7	23.4	30.0	31.8	47.7	63.6
Peak max current (A)	14.2	19.8	23.7	33.2	42.4	45.0	67.5	90.0
Temperature	Working 0-55℃ (If the ambient temperature is between 45~55℃, the average load should not exceed 80%). Storage -20℃-65℃							
Humidity	Working 40%-80% (No condensation) Storage Less than 93% (No condensation)							
Protection grade	IP20							
Control method	PWM sine wave vector control							

Regenerative braking		External, Optional, built-in or external
Feedback		ABZ incremental encoder, standard incremental encoder, and absolute encoder
Control mode		Position/Speed/Torque/Homing(return origin)
Control input		Up to 9 input terminals (optoelectronic isolation). Servo-enable, alarm clearance, forward rotation drive prohibited, reverse rotation drive prohibited, forward torque limitation, reverse torque limitation, zero speed clamp, internal speed selection 1, internal speed selection 2, mode switch 1, mode switch 2, forward jog, backward jog, torque command direction setting, speed command direction setting, electronic gear selection 1, electronic gear selection 2, positional deviation clearance, pulse input prohibition, homing trigger, homing reference point
Control output		Up to 5 output terminals (optoelectronic isolation). Servo ready (S-RDY), alarm, zero speed, positioning complete, speed reached, torque reached, electromagnetic brake, servo in operation, positioning nearby, torque in limitation, speed in limitation, homing complete.
Encoder signal output	Signal type	A, B, Z differential output, Z signal open collector output
	Frequency dividing ratio	It can be configured through parameter PA78.
Position	Input frequency	Low speed pulse command port, differential input≤500kpps, single-ended input≤500kpps High speed pulse command port, differential input≤4Mpps
	Command mode	Direction + pulse sequence, CW+CCW pulse sequence,

		Two phase A/B orthogonal pulse, Internal position command
	Electronic gear ratio	Numerator, 1-32767 Denominator, 1-32767
	Command source	Internal position command, pulse command
Speed	Analog command input	Supported, -10V+10V input
	Command ACC/DEC	It can be set through parameters.
	Command source	Internal speed command, analog command
Torque	Analog command input	Supported, -10V+10V input
	Speed limitation	It can be set through parameters.
	Command source	Internal torque command, analog command
Special function		Homing, gain switch, mechanical resonance notch filter
Monitoring function		Rotation speed, current position, position deviation, motor torque, motor current, command pulse frequency, etc.
Protection function		Over speed, over voltage, over current, over load, braking abnormal, encoder abnormal, position out of tolerance, etc.
Featur	Speed frequency	≥1500Hz

es	response	
	Speed fluctuation ratio	$\leq \pm 0.03\%$ (Load 0-100%) $\leq \pm 0.02\%$ (Power -15%+10%)
	Speed ratio	1:10000

3 Installation and Wiring

3.1 Installation

When installing, operating and maintaining the RT series ac servo drive, please follow the instructions in the manual.

3.1.1 Installation environment

- Working temperature 0-55°C
- Working humidity below 80% RH (no condensation)
- Storage temperature -20°C-65°C
- Storage humidity below 80% RH (no condensation)
- Vibration below 4.9 m/s²
- Altitude below 2000m
- Install in a well-ventilated place with little humidity and dust
- Install in the place without corrosive gas, flammable gas, pyrophoric gas, oil gas, cutting fluid, cutting powder, or iron powder etc.

**WARNING**

- When in a vibration environment, to prevent transmitting vibration to the servo drive, please install the anti-rattle device on the mounting surface of the servo drive.
- When it has to be used in a corrosive gas environment, please try to keep corrosive gas out of the devices. The corrosive gas will cause the aging of electronic components and circuit boards.

3.1.2 Products appearance and dimensions

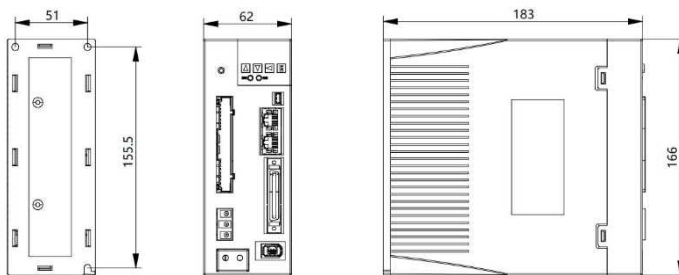

Figure 3-1 RT20-PA015H/020H Appearance and dimensions (Unit, mm)

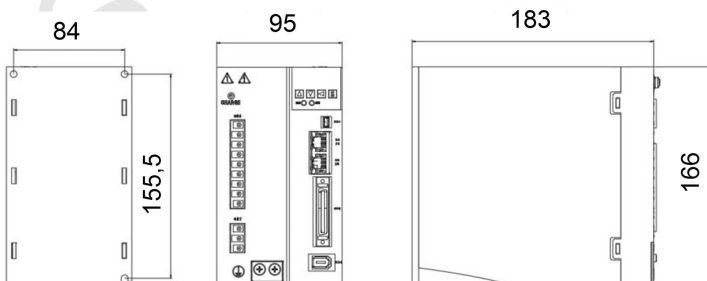

Figure 3-2 RT20-PA025H/035H/45H Appearance and dimensions (Unit, mm)

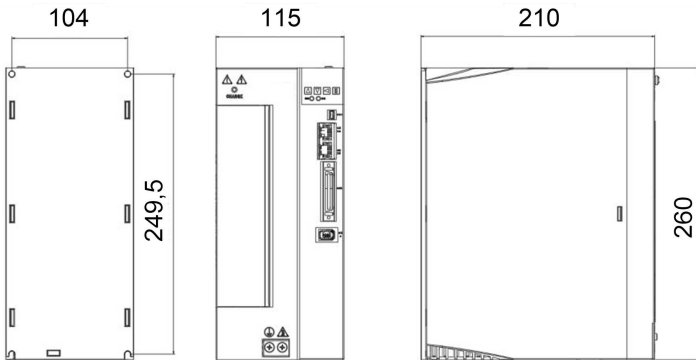

Figure 3-3 RT20-PA050H/075H/100H Appearance and dimensions (Unit, mm)

3.2 Wiring and terminals

3.2.1 Wiring diagram

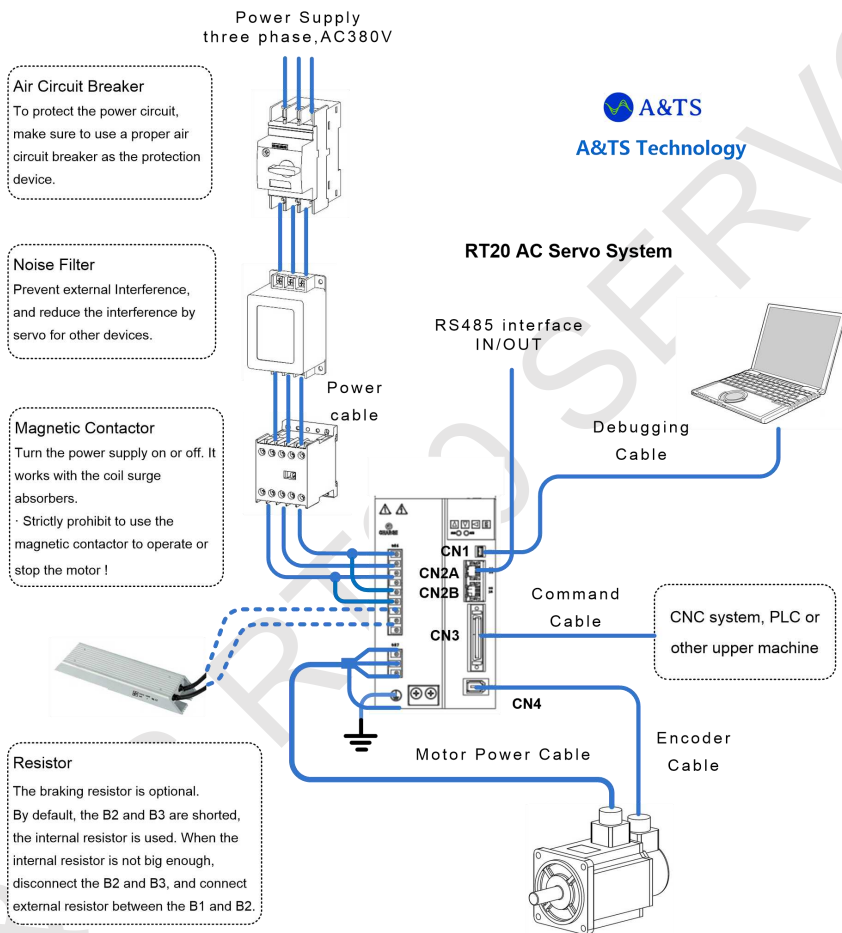

Figure 3-6 RT20-PA pulse series AC servo drive wiring diagram



DANGER

- Wiring operation should be performed by professional technicians.
- In order to avoid electric shock, after turn off the power, wait for more

than 5 minutes, and then disassemble the drive.

- Please connect the servo drive and servo motor after completing the installation, otherwise it may cause electric shock.
- Do not damage the cable, apply excessive pressure to it, hang heavy objects or squeeze, etc., otherwise it may cause electric shock.
- To avoid electric shock, please insulate the power terminal wiring.
- The specifications and installation methods of external wiring must be complied with all the local regulations.
- Make sure to ground the entire system.



WARNING

- Please wire correctly and carefully, otherwise it will cause abnormal operation of the servo motor and may cause injury.
- Do not make mistakes in the connection terminals, otherwise it may cause cracks and damage.

INSTRUCTIONS

- RT-STP is the RT Servo Tuning Program. It's a tuning and debugging software provided by the A&TS Technology. For more details, please contact with us at <https://www.a-ts.net>.

4 Display and Keyboard Operation

4.1 Basic operation

The operator panel adopts five LED tubes, two LED indicators, and four keys, as shown in the Figure 4-1.

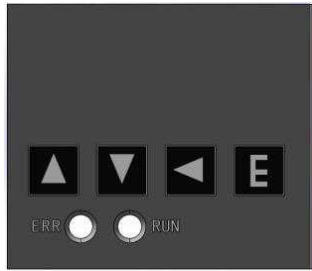

Figure 4-1 operation panel

ERR: The indicator lights up to show that the servo drive has an alarm.

RUN: The indicator lights up to show that the servo drive has been enabled and the motor is powered on.

Five Led tubes

The LED digital tube is used to display the states and parameters of the servo drive.

If the decimal point of the rightmost eight-segment digital tube flashes, it means there are alarms in the servo system.

Numeric display

It adopts 5 LED tubes to display numeric values. Some display items have prefix characters.

If the displayed value is negative, the decimal point of the displayed value will be lit up. And when the decimal value is greater than -10000, the highest digit displays a negative sign '-'. For example, 12345 indicates positive number 12345. .12345 indicates negative number -12345.

-2.345 indicates negative number -2345.

Four keys



Page up, to display page, increase serial number or value.



Page down, to display page, decrease serial number or value.



Return key, Return or cancel.



Enter key, Enter or OK.

Two LED indicator

PWR, Indicates that the main circuit of the RT servo driver has been powered on.

RUN: Indicates that the RT servo drive has been enabled and the servo motor is powered on.

NOTE

Keep pressing the page up or page down keys, the serial number (or value) will be increased or reduced continuously. And the longer the keep pressing is, the faster the increase or decrease is.

EXAMPLE

If you need to modify a parameter from 0 to 3000, please follow steps below.

Step one, keep pressing the page up key. The value increases from 0 continuously.

Step two, the value increases continuously, until the value reaches near the 3000, releasing the page up key.

Step three, press the page up or page down key discontinuously, to adjust the value until it reaches 3000.

4.2 Menu level one

The menu level one is used to select operating mode. Pressing the page up or page down key, it cycles between the 7 operation modes. Press Enter key to enter the menu level two, and press the return key back to the menu level one, as shown in the Figure 4-2.

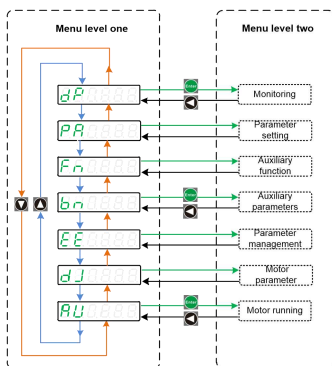

Figure 4-2 Menu level one

5 Running

Trial running without load

The purpose of trial running is to confirm whether the following items are correct.

- The servo drive power supply wiring
- The servo motor wiring
- Encoder wiring
- The servo motor running direction and speed

5.1 Wiring and inspection

Before power on, please check the motor.

- No load on the motor or motor shaft. Please disconnect the couplings if it is already installed on the machine.
- The motor must be fixed, or the ACC/DEC will move the motor.

- Do the wiring as per the following diagram, and check the following before power on.
 - Is the wiring correct? Especially whether the L1 / L2 / L3 wiring and U / V / W have the one-to-one correspondence with the motor?
 - Is the input voltage correct?
 - Is the encoder cable wiring correct?

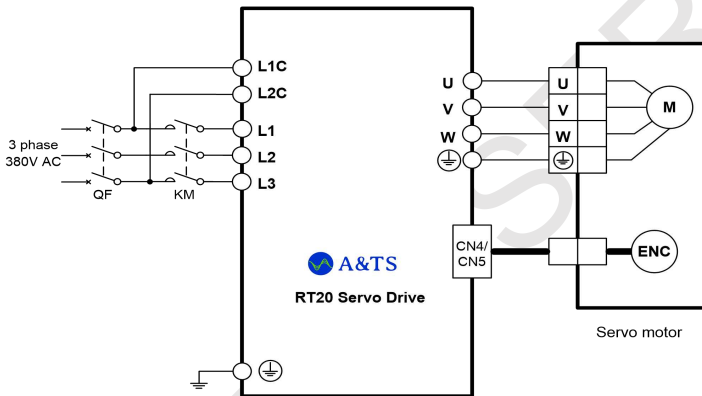

Figure 5-1 Servo drive wiring diagram

5.2 Electromagnetic brake

The electromagnetic brake is used to lock the vertical or slant workbench connected to the motor, to prevent the workbench from falling after the servo power supply is lost. To achieve this function, need to use a motor with brake. Brake can only be used to hold the workbench. Never use it to slow down or stop machine movement.

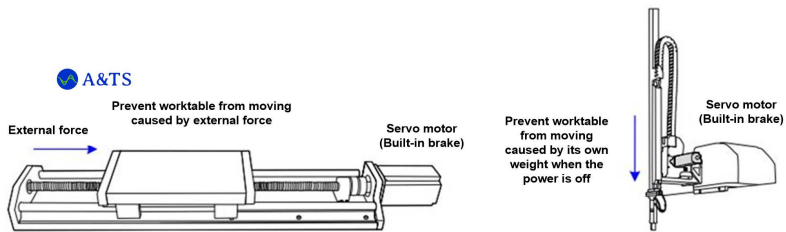

Figure 5-10 Electromagnetic brake application diagram

Figure 5-10 is the brake wiring diagram. Brake signal BRK of the drive is connected to the relay coil. The relay contact is connected to the brake power supply. The brake power supply is provided by user with enough capacity. It is recommended to install the surge absorber to suppress the surge voltage caused by the relay on/off operation. The diode can also be used as the surge absorber, but it will cause a little braking delay.

Usually, the servo is OFF after the motor stops moving completely. At this time, the motor is powered on to keep the position. From release condition to brake condition, the brake hold the condition for a while (time is set by the parameter PA47), then the motor is powered off.

During the running, when the motor speed is more than 30r/min, the motor current will be cut off, and the brake keeps the release condition. In order to avoid damage to the brake, wait for the motor decelerating from high speed to low speed, then use the brake. The actual waiting time is the shorter of the two, one is set by parameter PA48, and the other is the time that the motor decelerates to the speed set by the parameter PA49. The brake action specific time diagram, refer to Figure 5-10 to Figure 5-11.

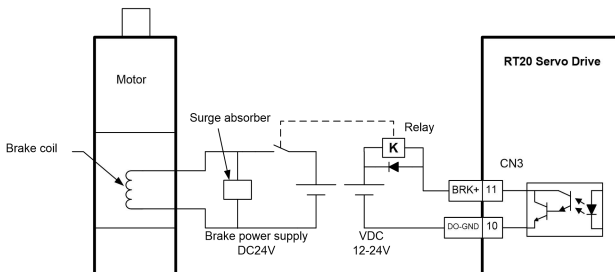

Figure 5-11 Electromagnetic brake wiring diagram

Table 5-9 Parameters related to the electromagnetic brake

Parameter	Name	Set value	Factory value	Unit
PA47	The waiting time of disconnecting the power, when the motor is motionless	0-5000	0	ms
PA48	The electromagnetic brake waiting time to brake, when the motor is running	0-5000	50	ms
PA49	The speed of brake action, when the motor is running	0-3000	100	rpm
PA50	The delay time of turning on the brake, when the motor is enabled	0-3000	20	ms

5.3 Regenerative braking resistor setting

When the motor speed and torque are in the opposite direction, energy is transmitted back from the servo motor to the servo drive, causing the bus voltage to increase. When the bus voltage rises to the threshold point,

energy can only be consumed through the braking resistor. And the braking energy must be consumed according to the braking requirements, otherwise the servo drive will be damaged. The braking resistor can be built-in or external, but cannot be used at the same time. The specifications of the braking resistor matched with the RT20 series servo system are as follows.

Table 5-7 The specifications of the brake resistor, for RT10 series drive

Servo drive type	Built-in braking resistor specifications		The minimum allowable resistance of external braking resistor (Ω)
	Resistance value(Ω)	Power(W)	
RT20-PA015H	40	80	40
RT20-PA020H	40	80	40
RT20-PA035H	50	100	40
RT20-PA045H	50	100	40
RT20-PA050H	40	200	40
RT20-PA075H	30	200	30
RT20-PA100H	30	200	30

When alarm Err14 (braking failure) or Err16 (regenerative resistor braking rate is too high) occurs in the servo drive, first appropriately reduce the acceleration and deceleration time of the servo system. If the alarm still occurs, an external braking resistor needs to be used. Connect the two terminals of the braking resistor to terminals B1 and B2 respectively, and remove the short-circuited cable between terminals B2 and B3. After the braking resistor is connected, the relevant parameters need to be set correctly, otherwise it may cause braking failure.

Table 5-8 The parameters related to regenerative braking resistor

Parameter	Name	Set	Factory	Parameter
-----------	------	-----	---------	-----------

		value	value	description
PA51	Braking resistor selection	0-3	0	0-Internal braking resistor 1-External braking resistor
PA69	External braking resistor resistance	1-750	50	Ohm(Ω)
PA70	External braking resistor power	0-10000	50	Watts(W)

**DANGER**

- The resistance value of the regenerative braking resistor used in the servo system should not be less than the minimum allowable value, otherwise it may cause an Err38 alarm or damage to the servo system.
- Do not install the external braking resistor on combustible materials, otherwise it may cause a fire due to high temperature.
- The braking resistor must be connected after the servo drive is powered off for at least 10 minutes, and the internal high voltage must be discharged before it can be connected.
- The smaller the resistance of the braking resistor, the greater the braking current, the greater the power of the braking resistor required, and the greater the braking energy. Never use a braking resistor with a resistance smaller than the minimum allowed resistance.
- The appropriate resistance value of the braking resistor can be determined through experiments. Change the resistance value from large to small until the alarm no longer occurs in the servo drive.

6 Adjustment

6.1 Summary

The servo drive needs to drive the motor as fast as possible, and to track the commands from the upper machine or internal settings. To achieve it, the servo gain shall be adjusted reasonably.

The servo gain is set by a combination of multiple parameters (position loop, speed loop gain, current loop, load rotation ratio of inertias, etc.), and they affect each other. Therefore, the servo gain setting must take the balance of each parameter value into the consideration.

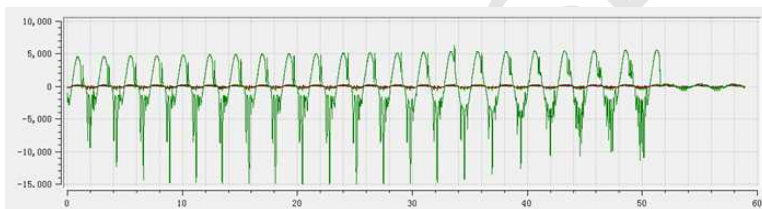

The general procedure for adjusting the servo gain is as follows.

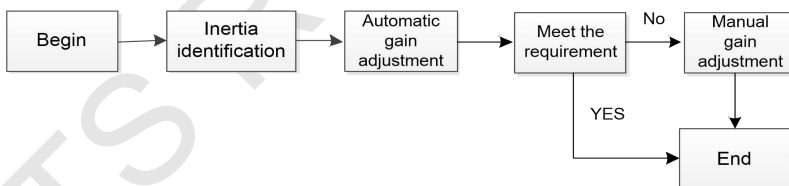

Figure 6-1 Gain adjustment flowchart

7 Function Application

7.1 Homing (return origin)

The return origin (homing) is to let the machine move to a specific starting point, which is used as the reference origin position for succeeding movement.

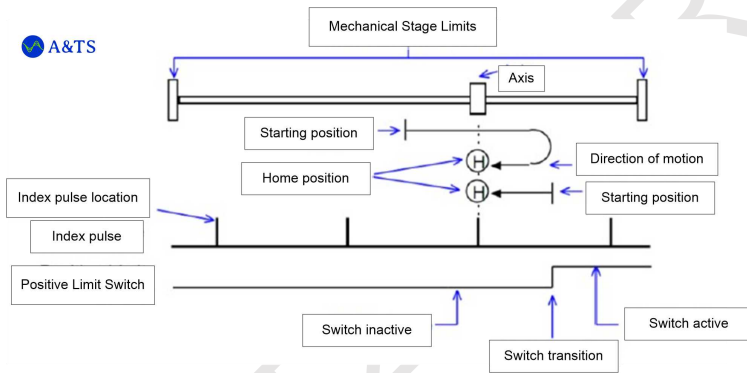

Figure 7-1 Principle of the homing/return origin

7.2 Control mode switch

The control mode switch function refers to switching the control mode by setting the ON/OFF of the two input terminals. This function enables real-time switching between 'position, speed and torque' control modes.

8 Parameters

8.1 Parameter list

INSTRUCTIONS

- The applicability column indicates which control modes are applicable. P means position control is applicable, S means speed control is applicable, T means torque control is applicable, ALL means position, speed and torque control are applicable.
- The parameter number with '★' means that the parameter value needs to be saved after being modified, and it will not take effect until the servo is restarted and powered on. If there is no '★' after the parameter number, it means that the parameter value will take effect immediately after being modified.
- When there is '▲' after the parameter value, it means that the factory value of the parameter may be different depending on the model of the servo drive.

Parameters usually used are

Trial running parameters: PA4, PA21, PA53

Motor parameters: PA1, PA18, PA45, PA61

Operating parameters: PA4, PA81, PA84

Tuning parameters: PA5, PA6, PA9, PA29, PA33, Fn40

9 Fault Alarm

9.1 Alarm code list

INSTRUCTIONS

1. Adding '★' after the alarm code means that the alarm cannot be cleared by resetting, and it can only be cleared after removing the cause of the alarm and power cycle again.

2. When the digital tube displays Err x, 'x' represents the alarm code, and the user can view the alarm through the current interface of the digital tube. When the digital tube displays r 0. (a decimal point flashes in the lower right corner of 0, which means there is an alarm currently), the user can view the alarm through the 19Err value under the Dp menu.

Table 9-1 Alarm list

Alarm code	Alarm name	Description
0	Normal	No alarm
Err 1	Over speed	Servo motor speed exceeds the set value (PA23)
Err 2	Main voltage is under overvoltage	Main circuit power supply voltage is too high
Err 3	Motor vibration detected	The RT servo drive has detected vibration that exceeds the set threshold
Err 4	Position out of tolerance	The value of the position deviation counter exceeds the set value (PA17)
Err 5	Motor average load current alarm	The average load current of the motor is too large
Err 6	Speed amplifier	Speed regulator is saturated for a long time

	saturation fault	
Err 7	CCW, CW servo drive prohibition is abnormal	CCW and CW servo drive prohibition inputs are all OFF.
Err 8	IPM over temperature alarm	IPM temperature exceeds the set value
Err 9A/B/C	Encoder A/B/Z phase error	Encoder A/B/Z phase signal error
Err 10★	Motor parameter error	Motor parameter value is out of range
Err 11★	IPM is faulty	IPM (Intelligent Power Module) module is faulty
Err 12	Over current	The motor current is too large
Err 13	Over load	The servo drive and motor are overloaded (instantaneous overheating)
Err 14	Braking fault	Brake circuit is faulty
Err 15	Encoder count error	Encoder count is abnormal
Err 16	Braking resistor braking rate is too high	Braking rate is outside the range of reasonable values
Err 18	Absolute encoder alarm	The absolute encoder communication is faulty
Err 19★	Absolute encoder battery failure	Battery voltage is lower than 2.5V, multi-turn position information has been lost
Err 20★	EEPROM error	EEPROM error
Err 21★	Phase A current sampling error	Phase A current sampling error
Err 22★	Parameter value is out of range	There is servo parameter value out of specified range.
Err 23★	Phase B current	Phase B current sampling error

	sampling error	
Err 24★	Absolute encoder parameter read/write error	Motor encoder EEPROM parameter error
Err 25	Absolute encoder feedback is abnormal	Absolute encoder feedback frequency is too high
Err 26	IO input terminal function configuration is abnormal	Different IO input terminals are configured with the same function
Err 27	Absolute encoder battery alarm	Battery voltage is lower than 3.1V, the battery voltage is low
Err 28	Absolute encoder communication timeout alarm	Absolute encoder communication feedback timed out
Err 29	Torque overload	Motor load exceeds the value and duration set by user
Err 30★	Encoder Z pulse lost	Encoder Z pulse signal is lost
Err 31★	Encoder UVW signal error	Encoder UVW signal is incorrect or does not match with the encoder
Err 32★	Encoder UVW signal encoding is invalid	UVW signal keeps at all high level or all low level
Err 33★	Dynamic memory allocation error	Dynamic memory allocation error
Err 34★	Flash reads CRC error	Flash reads CRC error
Err 35★	Motor adaptation error	A non-adaptive motor is connected to the RT servo drive
Err 36	Watchdog error	RT servo drive internal watchdog error.
Err 37★	Motor initial zero position lock error	Motor initial zero position lock error

Err 38★	External braking resistance value is incorrect	The resistance of the external braking resistor is less than the minimum allowable value
Err 51	Multi-turn data exceeds the set value	Multi-turn data exceeds the set value
Err 52	Main power supply under voltage alarm	In the enabled state, the bus voltage is lower than 245V
Err 53	AC main power supply of servo system loses power	The power supply lines L1, L2, and L3 of the RT servo drive are powered off.
Err 54	AC main power supply of the servo system is phase loss.	The power supply lines L1, L2, and L3 of the RT servo drive are phase loss.
Err 55★	Dynamic braking overcurrent	Dynamic braking overcurrent error
Err 56	Internal D5V undervoltage	The voltage supplying the control board is less than 5 V
Err 61	Fan alarm	A fan alarm has appeared.
Err 62	Motor speed error is too large	The difference between command speed and actual speed is too large
Err 63	ABZ incremental encoder UVW abnormality	ABZ incremental encoder UVW abnormality
Err 64	Multi-turn value overflow alarm	The actual multi-turn value of the motor overflow
Err 65	Motor average load current alarm	The continuous current reaches 1.2 times the rated current for 40s, 1.5 times for 30s, and 2 times for 10s.
Err 66	Motor average load current alarm	The continuous current reaches 1.15 times the rated current for more than 400s.
Err 67	Phase current alarm 1	The phase current exceeds threshold 1.

Err 68	Phase current alarm 2	The phase current exceeds the maximum current of the servo IPM.
Err 69	Phase current alarm 1	The phase current exceeds threshold 1.
Err 70	Phase current alarm 2	The phase current exceeds the maximum current of the servo IPM.

The End



A&TS Technology Corporation Limited

Address: Building A, 1970 Creative Industry Park, Ping'an road, Longhua District, Shenzhen, China 518110

Web: <https://www.a-ts.net>

Tel: +86-27-83520855

Mobile: +86-13322987810 (WhatsApp)

Email: contact@a-ts.net

service@a-ts.net

For users or end customers, please contact your local supplier or A&TS company service directly. The information in this publication is reviewed regularly and any necessary corrections are included in subsequent editions. The contents of this document are to be updated without notice. Please contact us to get the latest version.

© A&TS Technology Copyright. All rights reserved.

Published in Mar. 2026

Reprint or copy is strictly forbidden